

# Visa Protocols for Controlling Interorganizational Datagram Flow

DEBORAH ESTRIN, MEMBER, IEEE, JEFFREY C. MOGUL, AND GENE TSUDIK, STUDENT MEMBER, IEEE

**Abstract**—The increasing use of internetworking protocols to connect administratively heterogeneous networks has raised the question of how an organization can control the flow of information across its network boundaries. One method for doing so is the use of *visas*, a cryptographic technique for authenticating and authorizing a flow of datagrams. This paper presents and evaluates two *visa* protocols—one that requires distributed state information in gateways and one that uses additional encryption operations instead of distributed state. Applications for such *visa* protocols include access control, accounting and billing for packet transit, and network resource management.

## I. INTRODUCTION

THE local-area and long-haul networks of many distinct organizations can be joined together into an *internetwork* through which datagrams flow without regard to organizational boundaries. The transparency of an internetwork is both a blessing and a curse: a blessing because it provides universal connectivity without requiring application-specific gateways, and a curse because it makes it much harder to control the flow of information between organizations.

Early internetworks ignored the issue of control, either because they connected organizations within a larger administrative unit (such as a single corporation, university, or governmental body) or because they connected research institutions with little need to limit information flow. Current internetworks connect organizations that may have competing interests. Thus, we can no longer ignore the need for controlling interorganizational information flow. Similarly, in a multiorganization internetwork, costs must be billed to individual organizations or departments, resulting in a growing need for secure protocols to account for datagram traffic.

One approach is to introduce controls at a number of levels in the protocol hierarchy. We would like to preserve the useful properties of datagram-level transparency by controlling the flow of individual datagrams. We as-

sume that higher-level controls will be implemented as appropriate to the particular applications and organizations involved.

To provide datagram-level control, Estrin and Tsudik have proposed the *Visa* scheme [4]. Conceptually, a secret key is used to compute an unforgeable mark placed on a datagram to assure a gateway that interorganizational transmission of that datagram is properly authorized. This mark is called a *visa*, by analogy with the stamp made on a passport that allows the bearer to cross a border. We bind each visa to a single datagram in order to guarantee the authenticity of datagram contents. Visas were first suggested by Reed, and documented by Mracek [10]. A detailed analysis of the issues associated with interorganizational networks, as well as the motivations behind the *visa* scheme, can be found in [5].

In general, a host on a visa-controlled network that wants to communicate across its organizational boundary initially engages in a high-level authorization and authentication procedure with the Access Control Servers (ACS's) on both source and destination networks (see Fig. 1). The need for (and particulars of) ACS authorization is determined individually by the owners of the endpoint networks. When a source-destination connection has been approved by an ACS on each network, the ACS's allocate *visas* to the requesting host. The host uses the visas to stamp all datagrams belonging to that connection. The border gateways ("visa-gateways") of the endpoint organizations check all datagrams for appropriate stamping, and pass authorized datagrams until a visa expires or is revoked. Each gateway checks the authorization of a datagram to enter or exit the attached network, not whether the datagram is authorized to travel all the way from source to destination. Visa-gateways may also use visa information to ensure that the proper parties are billed for the cost of carrying the datagrams.

In this paper we present two variations of the protocol originally proposed by Estrin and Tsudik [4]. One is an improved version of the original ("stateful") protocol, in which the ACS's distribute visas to the gateways involved. The other ("stateless") variant avoids the necessity for distributed state, but requires additional encryption steps. We then analyze the drawbacks and advantages of these two protocols based on conventional single-key ("private-key") cryptography. (A public-key variation of the stateless protocol is discussed in [6].)

Manuscript received August 8, 1988; revised January 15, 1989. This work was supported in part by the National Science Foundation, Presidential Young Investigator Award, with matching funds from GTE Inc. and NCR Inc., and by the University of Southern California Faculty Research Initiation Fund. Portions were funded by the Digital Equipment Corporation Western Research Laboratory.

D. Estrin and G. Tsudik are with the Department of Computer Science, University of Southern California, Los Angeles, CA 90089-0782.

J. C. Mogul is with Digital Equipment Company, Western Research Laboratory, Palo Alto, CA 94301.

IEEE Log Number 8927174.

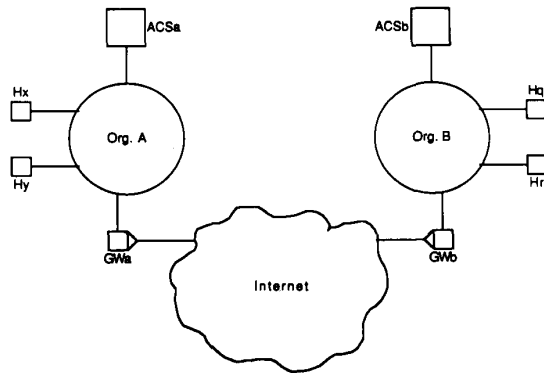

Fig. 1. Two interconnected organizations running the visa protocol.

### A. Policies

Visas are a *mechanism* for authenticating the source, destination, and contents of a datagram. Authentication in itself is not an end but a means for implementing a policy, such as access control or accounting. An access control policy, applied to datagrams, requires a gateway to determine if the authenticated parties are indeed authorized to communicate. (Visa protocols described in this paper allow only authorized pairs of hosts to be authenticated.) An accounting policy requires a gateway to charge the resources used to an authenticated host; in this context a visa is a certificate that the host has promised to pay its bills. A resource management policy requires a gateway to ensure that the authenticated host has not used up its quota of resources (for example, if datagram charges must be prepaid).

In the visa protocols we describe, gateways do not bear sole responsibility for making policy decisions. By issuing a visa, an ACS has precomputed a decision such as “these hosts are allowed to communicate,” or “this host can be trusted to pay its bills.” The task of a gateway is reduced to ensuring that the visa is valid and is being used correctly; the expensive part of the policy implementation is done once per connection, by the ACS, rather than once per datagram, by the gateway.

This paper emphasizes problems of access control; visa protocols described here are designed for that purpose. Accounting and resource management appear to be simpler problems; for example, one may tolerate moderate “leakage,” resulting in slightly incorrect bills, if the net result is a lower overhead cost for doing the billing. Also, it is necessary to authenticate only one party (the one who is paying) if the only application is billing. Therefore, in an environment where visas are used for accounting and not for access control, somewhat different protocols may be appropriate; this is the subject of work in progress [7].

### B. Network Environment

We will assume that the internetwork closely follows the model of the DARPA Internet [15], which is substantially similar to the Open Systems Interconnection (OSI)

model [19], [22]. The essential features of the environment are as follows.

- Hosts are autonomous and cannot necessarily be trusted.
- Organizational networks are connected by gateways; between any pair of hosts in different organizations there are at least two gateways, one belonging to each of the organizations. Conceptually, the connection between two organizations is a pair of half-gateways connected via a trusted link. Each half-gateway can be trusted by its own organization but not by any other organization.
- All information flows via datagrams. A datagram consists of a *header* that includes addressing information and a data segment that is not intelligible to gateways.
- A datagram may flow through several “untrusted” organizations on its way to the destination.
- Host addresses, both source and destination, can be forged. It is not possible (using hardware methods) to determine reliably which host actually sent a datagram or to prevent a datagram from being seen by unauthorized hosts; in other words, many Local Area Network (LAN) technologies can be wiretapped.
- Duplicate datagrams and occasional lost datagrams are natural consequences of using a datagram network. Therefore, if a malicious host duplicates datagrams from time to time, we are willing to accept the covert channel created by this method.

### C. Design Goals

The purpose of the visa protocols is to allow an organization to grant certain privileges to select trusted hosts and to provide a means for preventing the abuse of such privileges. This is but one component in the provision of complete security. The success of a visa-based system assumes the ability to trust certain hosts not to misuse visas.

Our primary goal is to allow an organization to control the transmission of datagrams to and from hosts in other organizations. If the specific hosts involved can be trusted, then we can meet a stronger goal: we can control the transmission of datagrams to and from a *specific* host in another organization. In a datagram network, as opposed to a circuit-switched network, the only information available about a datagram must be attached to the datagram rather than inferred from the route the datagram follows. Therefore, we can state these goals more directly as follows. An organization can guarantee that: a datagram can leave the source organization  $O_{src}$  only if  $O_{src}$  has authorized the sender to send datagrams to the apparent destination host, and a datagram can enter the destination organization  $O_{dst}$  only if  $O_{dst}$  has authorized the sender to send datagrams to the apparent destination host. Visa protocols also allow each controlling organization to revoke the privileges it has granted.

Another goal is to add no cost to intraorganizational datagram traffic, nor to impose additional security measures upon hosts that do not participate in interorganizational traffic. Similarly, we wish to limit the overhead im-

posed upon organizations who are not concerned with controlling external access.

Finally, we want to minimize the costs imposed by the visa protocols, including: additional per-packet processing time in both hosts and gateways, additional storage requirements for hosts and gateways, extra datagrams sent during connection setup, increments in the length of datagrams (increasing length increases latency and decreases throughput), costs of recovering from gateway crashes, and complexity of the implementations.

The security of visa protocols depends upon the secure operation of participating ACS's, gateways, and hosts, as well as upon secure distribution of visas from ACS's to gateways and hosts. Discussion of mechanisms to implement such security is beyond the scope of this paper and can be found elsewhere [13].

#### D. Structure of this Paper

The remainder of this paper is organized as follows. Section II describes the notation and the general features of the visa protocols. Section III describes an improved version of the original single-key visa protocol (with state information in gateways). Section IV describes a stateless variation of the single-key protocol. Section V presents an evaluation and analysis of the two protocols. Experimental results are discussed in Section VI. Section VII touches upon several design issues that space does not permit us to cover in detail. Finally, Section VIII summarizes our findings.

## II. VISA PROTOCOLS

### A. Notation

We use the notation of Needham and Schroeder [13] to show encryption operations; for example,

$$\{F_0, F_1, \dots, F_n\}^K$$

denotes the encryption of a record containing fields  $F_0$  through  $F_n$  with key  $K$ . For active entities involved in the visa protocols, we use the symbol  $H$  to denote a host,  $O$  to denote an organization,  $ACS$  to denote an Access Control Server, and  $GW$  to denote an interorganization gateway.  $VKEY$  denotes a visa key issued by an ACS for use in creating visas in the stateful visa protocol, and  $V$  denotes a visa issued by an ACS for use in the stateless protocol.

Any of these symbols can be subscripted *src* to indicate the *source* of a datagram, *dst* to indicate the *destination* of a datagram, *trans* to indicate an organization through which a datagram passes *in transit* between the source and destination organizations, *exit* to indicate the gateway via which a datagram *exists* an organization, and *entr* to indicate the gateway via which a datagram *enters*. For example,  $H_{dst}$  denotes the destination host of a datagram, and  $GW_{exit}$  denotes a visa-gateway of the source organization through which a datagram leaves that organization's network.

### B. Components

Both visa protocols involve the following components: visas, access control servers, gateways, and hosts. These components and their responsibilities are described in this section.

1) *Visas*: A visa is an unforgeable stamp, created by cryptographic means, that is attached to a datagram. Its presence in a datagram indicates that the datagram is allowed to leave (or enter) an organization's network. A visa can be validated by the gateways of the organization that issued the visa (or that issued the means for its generation).<sup>1</sup> We describe how visa values are computed in Section II-D.

Each datagram carries at most two visas—one ( $V_{exit}$ ) for entering and exiting the source organization network, and one ( $V_{entr}$ ) for entering and exiting the destination organization network. This is necessary because the agents of one organization may not trust the agents of another organization, so source and destination visas for a datagram must be issued separately by the respective organizations.<sup>2</sup>

For our experimental modification of the Internet Protocol (IP) [16], visa-related information is carried in the OPTIONS field of the IP header, and so does not affect the normal processing of datagrams (see subsection 2). Datagrams traveling between visa-hosts that do not require visas (as decided by the ACS's of each organization) contain dummy visa values in the appropriate header fields to avoid calling undue attention to those datagrams that warrant visa protection; only the visa-gateways know which datagrams need to contain verified visas. Other IP gateways need not recognize IP options; therefore, visas are transparent to nonvisa gateways.

A visa key is allocated to an identifiable source-destination pair. In this discussion we assume that the uniformly available granularity of control and identification is a host; that is, visas are allocated for  $(H_{src}, H_{dst})$  pairs.

2) *ACS's*: An ACS is a host, usually dedicated for security reasons, that is primarily concerned with access control. Each visa-controlled organization has at least one ACS, responsible for authorizing hosts within its organization to communicate with hosts in other organizations.<sup>3</sup> Multiple ACS's may be necessary for availability and performance reasons. Specific policies regarding who may communicate with whom are embodied within ACS's and are not addressed directly in this paper.

<sup>1</sup>Estrin and Tsudik [4] originally used the term "visa" to indicate the cryptographic key used by the source and gateway to compute the unforgeable stamp. "Visa" now indicates the stamp itself, a usage closer to the English meaning of the word.

<sup>2</sup>In this paper we assume the use of *two-way visas*; that is, a single visa key is used to generate visas for datagrams traveling into and out of an organization's network between a particular source-destination pair. However, if an organization wants to carry out separate authorization/authentication dialogs for incoming and outgoing traffic, it may do so—at the cost of double the connection setup overhead.

<sup>3</sup>If a participant organization does not have an ACS, its hosts will still be able to communicate with the hosts of other organizations, although the organization in question will be subject to risks associated with the uncontrolled access.

Each ACS knows of a number of local visa-gateways that enforce its decisions. ACS's are trusted and assumed to defend against attempted abuse. The security of the overall protocol requires that ACS's be secure and that they employ an authenticated and secure channel for communication with local hosts and gateways.

3) *Gateways*: A gateway is a host dedicated (for reasons of performance and security) to packet forwarding. Gateways that use the visa mechanism to enforce access controls are called visa-gateways.<sup>4</sup> All interorganization connections must be implemented with visa-gateways. Each visa-gateway knows the ACS's in its organization, is willing to accept visa assignments from these ACS's, and trusts their decisions about authorizing and terminating sessions. A visa-gateway allows any external party to communicate with any registered, internal ACS; similarly, the gateway allows all registered, local ACS's to communicate with any external party.<sup>5</sup>

Assuming that each organization employs a visa-gateway, each interorganization datagram travels through at least two such gateways. Each visa-gateway is equipped with some means of verifying a visa. Visa protocols described in subsequent sections vary in the particular validation techniques used.

A visa-gateway must scrutinize every packet it receives; datagrams without visas cannot be forwarded (except for those to or from trusted entities of the gateway's own organization). In [6] we describe a mechanism for a gateway to inform a host that visas are required for an interorganizational connection. Datagrams must be dropped if they contain neither a valid visa nor a "dummy" placeholder visa indicating that a host wishes to be informed via this mechanism.

If the two organizations' networks are not directly connected, packets will pass through the gateways of transit networks. Visa-gateways in a transit network trust each other, and transfer transit packets via secure channels to prevent unauthorized entrance or exit; this is described in more detail in [6]. Nonvisa-gateways in transit networks treat visa datagrams as regular internet packets.

4) *Hosts*: The source host ( $H_{src}$ ) of an interorganization connection must obtain a pair of visas—one from the ACS of its organization ( $ACS_{src}$ ) and one from the ACS of the organization ( $ACS_{dst}$ ). These visas must be included in the header of every datagram sent from  $H_{src}$  to the destination host,  $H_{dst}$ .

A host, unlike a gateway, does not have to have reliable knowledge of the local ACS's address; this may instead be supplied by a gateway when a host attempts to communicate across the organizational boundary (see [6]). The host must still use an authentication protocol to make sure it is really talking to the ACS.

<sup>4</sup>Some gateways may not be involved in visa-enforcement (for example, gateways internal to an organization). We therefore distinguish between *visa-gateways* and *nonvisa-gateways*.

<sup>5</sup>Such trust is reasonable because ACS's are known to be defensive and to enforce organization policy. Other special servers such as a name server may be given a similar "carte blanche" for external communication if they too are known to be secure.

Since datagram reception is a passive operation, the destination host ( $H_{dst}$ ) is not required to initiate any actions. Of course, in almost any protocol, datagrams flow in both directions, so each host is both a source and a destination. Therefore, to avoid additional overhead, we assume that an organization allows its ACS to allocate *two-way* visas automatically *if* authentication of the remote destination is not required.

By themselves, visa protocols do not provide for multilevel security, nor do they eliminate a variety of covert channels. In the absence of additional host-level, nondiscretionary controls, an authorized host may still subvert these protocols by "willingly" serving as a conduit for communications between unauthorized hosts.

### C. Establishing Authorization

In the scheme originally proposed in [4],  $H_{src}$ , when opening a connection to  $H_{dst}$ , initially sends a datagram with an "empty" visa; if the datagram reaches a visa-gateway, the gateway replies with a REJECT message directing  $H_{src}$  to an appropriate ACS. The source host requests a visa from that ACS, which (if necessary) obtains visas from ACS's in other organizations, distributes visa information to the appropriate gateways, and returns the valid visas to  $H_{src}$  (and, possibly,  $H_{dst}$ ). The purpose of the REJECT mechanism is to accommodate hosts that do not know when a visa is required.

However, a host may already know that its intended destination is in a different organization, either because it has previously communicated with that host (and cached the fact that at some point it had received a REJECT), or it may have discovered this through some external mechanism (for example, a name server). If so, it may communicate immediately with an ACS of its own organization to obtain visa, rather than going through the extra two-packet step of attempting to send the initial datagram and receiving a REJECT. The REJECT mechanism is a "fallback" mechanism to inform hosts that they are crossing an organizational boundary, rather than an integral part of connection setup. Note that a REJECT may actually be sent in the middle of a connection, if a visa expires or if a gateway table overflows and active visas are purged. For further detail on the REJECT mechanism, see [6].

Many interorganizational connections are brief: in the Internet, for example, most such connections are either electronic mail transfers, which usually involve no more than a dozen datagrams, or name translations, which are even briefer. A visa authorizes datagram transmission between two hosts, not a specific high-level connection. Therefore, we do not require hosts to obtain a fresh visa for every connection, nor do we expect hosts to inform the gateways when a visa-controlled connection terminates. "Least-recently-used" mechanisms can keep gateway caches or tables from filling with stale data. We rely upon the ACS's to enforce specific visa expiration and revocation policies.

#### D. Computing Visa Values

A visa value must protect against subversion in two ways. First, it must prove that the source of a datagram is authorized to send datagrams to the destination (in other words, that an imposter cannot pose as an authorized source merely by faking its internet address). Second, it must prove that the particular data carried in a datagram are the same data that the source intended to send to the destination. We refer to this second proof as "data integrity." In general, transformation of a data value to guarantee its provenance is known as a "digital signature" [3], [13], [18].

The integrity of a visa protocol depends on the method by which the visa values are calculated. To avoid "playback attacks," a visa value must be derived from a visa key and some unique property of each individual datagram. In other words,  $visa = F(visakey, datagram)$  where  $F$  is some cryptographically strong one-way (trapdoor) function that computes a cryptographic signature of the datagram. The function chosen for  $F$  must have good cryptographic properties, yet be inexpensive to compute. In this paper, we assume that  $F$  is a function such as the DES-based Message Authentication Code (MAC) [1].

Note that the sizes of both visas and visa keys affect the cost of computing visas; they also affect the likelihood that a visa system can be compromised. Unfortunately, although signatures and keys with larger sizes are more resistant to attack, they also increase the cost of computing  $F$ .

### III. SINGLE-KEY PROTOCOL WITH STATE INFORMATION IN GATEWAYS

This section describes the first single-key variation of the visa protocol, derived from the one proposed in [4]. In this protocol, all nontransit visa-gateways along all possible routes of a datagram must contain an appropriate entry in their tables. Therefore, in order to set up a path between two hosts, each such gateway must communicate with its organization's ACS to obtain the visa key for the source-destination pair.

This is the distinctive feature that separates this protocol from the stateless protocol discussed later in the paper. Here, each component (hosts, ACS's, and gateways) must maintain a *visa-table*, a database of active visa information. An entry in the visa-table pertains to the state information of a specific interorganization connection. In the stateless protocol, in return for slightly greater per-packet header length and encryption overhead, only the hosts must maintain reliable databases. The stateless-protocol gateways use caches to improve their performance, without requiring extra packet exchanges for database maintenance.

#### A. Creation and Distribution of Visa Keys

In this variant, a *visa key* is a unique value (a cryptographic key) assigned by an ACS to a session between two hosts on distinctive networks. The visa value carried

in the datagram is computed as a cryptographic signature of a datagram.

Whenever an ACS issues a visa key to a host via a VISAGRANT message, it must also send the visa key to all the border visa-gateways for the organization. If there is more than one ACS for an organization, it might also be useful to distribute the visa information to other ACS's so as to improve the availability of the information in the case of host failures.<sup>6</sup>

#### B. Verification of Visas

Once the visa keys are in place,  $H_{src}$  is able to send datagrams to  $H_{dst}$ . Every outgoing datagram addressed to  $H_{dst}$  is stamped with both exit and entrance visas,  $H_{exit}$  and  $V_{entr}$ . Both values are calculated as described above.  $GW_{exit}$  and  $GW_{entr}$  each calculate  $V_{exit}$  and  $V_{entr}$ , respectively (using the values  $VKEY_{exit}$  and  $VKEY_{entr}$  from their visa-tables), and compare them to the values found in the datagram. If the two values match, the datagram is passed, otherwise it is REJECTED. This procedure simultaneously verifies that a visa is valid, that a visa allows  $H_{src}$  to communicate with  $H_{dst}$ , and that the contents of a datagram are those that were sent by  $H_{src}$ .

#### C. Connection Revocation

Because many protocols do not have an explicit ending phase (for example, the delta-T protocol [8], [21]), an ACS imposes time limits on visas that it issues. The time limits are passed along with the visa keys to the local visa-gateways, which delete the connection's entry from their visa-tables as soon as the connection times out. A host that anticipates exceeding the time limit of its current visa may request a visa extension before the visa expires, in order to avoid reapplication delays. In addition to exceeded time or resource limits, a REVOKE message may be used to revoke a visa. A REVOKE message, triggered by a request from  $H_{src}$ ,  $H_{dst}$ , or an ACS itself, is sent to the appropriate gateways by the ACS. The system is vulnerable to the extent that REVOKE messages may be dropped or delayed.

#### D. Problems

The main drawback of this protocol is that each visa-gateway between a pair of communicating hosts must include a visa-table entry for that host pair. This is undesirable for the following reasons.

- The setup mechanism used to get visas into the visa-tables generates a number of extra datagrams. At least two visas must be sent from ACS's to gateways, requiring at least that many datagrams.<sup>7</sup>

- One of the commonly held advantages of datagram networks is their ability to efficiently and dynamically switch packets along multiple routes, thus providing some

<sup>6</sup>If one-way visas are used, this same procedure will be carried out in reverse when the first return datagram is generated.

<sup>7</sup>This is in addition to whatever datagrams need be exchanged between the source host and the ACS's involved in order to authorize the visas.

immunity to failed gateways or links, and spreading load across the available bandwidth of a well-connected network. In order to take advantage of routing redundancy when using visas, every local visa-gateway along any potential route is given the visa information at setup time, which can potentially result in  $(M + N)$  datagrams to be sent by source's and destination's ACS's to their respective visa-gateways ( $M$  and  $N$  are the number of visa-gateways in each of the organizations' networks).

- A gateway must maintain its visa-table, which can potentially be quite large ( $O(n)$  in the number of communicating host pairs). Table overflow is not fatal, but when a purged entry turns out to be active, part of the setup mechanism must be reinvoked. The storage overhead of visa-tables is per visa-gateway, not simply per gateway pair, since the two gateways belong to different organizations and cannot trust one another.

- When a visa-gateway crashes, unless its visa-table is held in stable storage, it must be reloaded from the organization's ACS. If the ACS crashes as well, the setup mechanism must be reinvoked for every active connection. The resulting burst in overhead traffic is likely to create congestion.

#### IV. STATELESS SINGLE-KEY PROTOCOL

In order to avoid some of the problems listed in Section III-D, we present a different visa protocol without the requirement that the gateways know about every visa. This means that we no longer have to pay the costs for setting up and storing visa-tables, although the per-packet processing costs are slightly higher, and revocation is more disruptive.

The primary difference between the two protocols is where the gateways find the authorization information. In the first, or *stateful* protocol, a gateway keeps all authorization information about active connections in its visa-table, which must be loaded by the ACS. In the second, or *stateless* protocol, the authorization information is attached by cryptographic means to each datagram; a gateway needs no authorization database. In effect, the visa information is piggybacked on each datagram rather than being directly communicated between ACS's and gateways. A digital signature system is used to maintain the integrity of this piggybacked information, and caching is used to reduce the amount of encryption overhead.

The particular protocol described here uses a single-key (private-key) cryptosystem such as DES [12]. A public-key version is quite similar; see [6].

##### A. Overview of the Stateless Mechanism

Suppose that  $H_{src}$  in  $O_{src}$  intends to send a datagram to  $H_{dst}$  in  $O_{dst}$ . Before sending the datagram,  $H_{src}$  must obtain a "visa-pair," consisting of an exit visa for  $O_{src}$  and an entrance visa for  $O_{dst}$ . It does so by contacting  $ACS_{src}$ , proving its identity, and asking for the appropriate visa-pair. If communication is authorized,  $ACS_{src}$  negotiates with  $ACS_{dst}$  to obtain an entrance visa for  $O_{dst}$ , issues the exit visa for  $O_{src}$ , and returns the visa-pair to  $H_{src}$ .

When  $H_{src}$  sends a datagram to  $H_{dst}$ , it first attaches the visa to the datagram (in a manner to be described shortly) in such a way that the visa-gateways can verify that the communication is authorized. This verification is done *solely* by applying cryptographic mechanisms to the datagram; the gateways need not maintain any databases.

A gateway can verify that a visa attached to a datagram is valid because the visa itself is signed by the issuing ACS. Signature is accomplished by encrypting the visa with a key known only to the ACS's and gateways of an organization; this is known as the "organization key." If the cryptosystem is secure, there is no chance of forgery.

It is harder to see how to protect against a malicious host that obtains a valid visa by monitoring the network and attaches this visa to its own datagrams. The trick is to have the source host sign every datagram using a secret session key known only to the source host and the visa-gateways (and to the ACS's trusted by those gateways). This key is embedded in the visa attached to the datagram, but because the visa is encrypted with the organization key, the session key is not available to interlopers. It is available to the visa-gateway as a side effect of verifying the authenticity of the visa. Because this key becomes known to  $ACS_{dst}$  and  $GW_{entr}$ , which may not be entirely trustworthy to  $H_{src}$ , a new signature key should be generated for each path, and different keys should be used for exit and entrance visas. In this protocol, the function  $FSIG(data)$  returns a signature of the data (for example, a DES-based Message Authentication Code) using the secret session key  $K$ .

##### B. Creation of Visas

$H_{src}$  begins the process of visa creation by generating two signature keys,  $KSIG1_{H_{src}}$  and  $KSIG2_{H_{src}}$ . It then contacts  $ACS_{src}$ , proves its identity,<sup>8</sup> passes the signature keys to  $ACS_{src}$ , and requests a visa-pair for use with  $H_{dst}$ . If communication is authorized,  $ACS_{src}$  negotiates with  $ACS_{dst}$  (passing  $KSIG2_{H_{src}}$ ) to obtain an entrance visa for  $O_{dst}$ , issues an exit visa for  $O_{src}$ , and returns the visa-pair to  $H_{src}$ .

The exit visa issued by  $ACS_{src}$  is

$$V_{exit} = \{H_{src}, H_{dst}, KSIG1_{H_{src}}, EXPIRATION\}^{KPRIV_{O_{src}}}$$

where  $KPRIV_{O_{src}}$  is the organization key for  $O_{src}$ , and  $EXPIRATION$  is a timestamp indicating when the visa expires; this allows an ACS to limit the lifetime of the visas it issues, since (in this protocol) explicit visa revocation is expensive (see Section IV-E). Any gateway belonging to  $O_{src}$  can verify that the visa was actually issued by  $O_{src}$  by computing  $\{V_{exit}\}^{KPRIV_{O_{src}}}$  and verifying that  $KSIG1_{H_{src}}$  produces the data signature for this datagram.

The entrance visa issued by  $ACS_{dst}$  is similar

$$V_{entr} = \{H_{src}, H_{dst}, KSIG2_{H_{src}}, EXPIRATION\}^{KPRIV_{O_{dst}}}$$

<sup>8</sup>Authentication methods for both single-key and public-key cryptosystems are described by Needham and Schroeder [13], [14].

and likewise can be verified by any gateway belonging to  $O_{dst}$ .

Note that because the visas are signed using a single-key system,  $KSIG1_{H_{src}}$  and  $KSIG2_{H_{src}}$  are kept secret.

Once it has a visa-pair,  $H_{src}$  can send datagrams. Assume that the datagram that it wishes to send is

$$DGRAM = \{HEADER, DATA\}$$

and that the header is

$$HEADER = \{H_{src}, H_{dst}, SEQNUM, otherfields\}$$

where  $SEQNUM$  is an ID that is unique to this datagram (these ID's can be recycled after a period at least as long as the expiration time of a visa).

$H_{src}$  must create a "safe" version of the datagram as follows:

$$DSIG_{exit} = FSIG(\{HEADER, DATA\}, KSIG1_{H_{src}})$$

$$DSIG_{entr} = FSIG(\{HEADER, DATA\}, KSIG2_{H_{src}})$$

$$SAFEHDR = \{H_{src}, H_{dst}, SEQNUM, V_{exit}, V_{entr},$$

$$DSIG_{exit}, DSIG_{entr}, otherfields\}$$

$$SAFEDGRAM = \{SAFEHDR, DATA\}.$$

$DSIG_{exit}$  and  $DSIG_{entr}$  are the data signatures. They are constructed so that all fields of the original datagram whose values must be checked are signed by  $H_{src}$ .<sup>9</sup> The safe datagram still includes the contents of the original datagram header in the unencrypted form, so it can be handled by nonvisa-gateways without additional mechanism. The new fields in the header are purely for the benefit of visa-gateways.

### C. Verification of Visas

Once the safe datagram has been constructed, it is sent along whatever route has been chosen by the usual means, and eventually reaches  $GW_{exit}$ .  $GW_{exit}$  must verify that 1)  $V_{exit}$  is valid, 2)  $V_{exit}$  allows  $H_{src}$  to send datagrams to  $H_{dst}$ , and 3) the contents of the datagram are those that were sent by  $H_{src}$ . The first condition is checked by computing

$$\{H_{src}, H_{dst}, KSIG1_{H_{src}}, EXPIRATION\} = \{V_{exit}\}^{KPRIV_{O_{src}}}$$

and verifying that the EXPIRATION time is reasonable and has not passed; also, if the visa is not valid, then the extracted  $KSIG1_{H_{src}}$  will be meaningless and consequently will not produce  $DSIG_{exit}$ . The second condition is checked by verifying that the  $H_{src}$  and  $H_{dst}$  extracted from the visa are those found in the datagram header. The third condition is checked by reconstructing the original HEADER and using the  $KSIG1_{H_{src}}$  extracted from the visa to check that

$$FSIG(\{HEADER, DATA\}, KSIG1_{H_{src}}) = DSIG_{exit}.$$

<sup>9</sup>It may be necessary to include copies of other header fields in the data signatures; see Section VII.

If all three conditions are met, then the datagram is what it purports to be, and SAFEDGRAM may be forwarded out of the organization.

Eventually, the datagram reaches  $GW_{entr}$ , which must verify that  $V_{entr}$  is valid,  $V_{entr}$  allows  $H_{src}$  to send datagrams to  $H_{dst}$ , and the contents of the datagram are those that were sent by  $H_{src}$ . These conditions are checked in the same way as they were checked for the exit visa. If they hold, the datagram can be delivered to  $H_{dst}$ .

### D. Avoiding the Cost of Visa Decryption

Because  $V_{entr}$  and  $V_{exit}$  are constant for as long as they do not expire, a gateway can cache both encrypted and decrypted values of the visas it uses. When a datagram arrives, a gateway uses the encrypted visa found in the datagram as a key to find a cache entry. If an entry exists, the gateway can use the contents of the decrypted visa, instead of paying the cost of visa decryption (the data signature must still be checked).

The size of the cache, unlike the size of the visa-tables used in the stateful protocol, is relatively unimportant. In the event of cache misses, only one additional encryption step per datagram is required, instead of a flurry of message exchanges.<sup>10</sup> If a gateway crashes and reboots, it need only retrieve its organization's key before continuing to process datagrams; no other messages need be exchanged.

### E. Revocation

In some cases it might be necessary to revoke a visa. The primary mechanism for revocation is the expiration time contained in the visa's cleartext. If visas are issued with relatively short lifetimes (on the order of minutes or hours), then it is unlikely that they will need to be explicitly revoked. In the stateful protocol, visas may be revoked explicitly. In the stateless protocol, if an ACS must revoke an unexpired visa, it needs to choose a new organization key and distribute that key to all boundary gateways and ACS's of its organization. Unfortunately, this invalidates all visas issued by that organization; because of this, and because a visa might expire before a connection is finished, all visa users must be prepared to reapply for new visas at any point in a connection.

### F. Variations on the Theme

Visas in the stateless protocol have more internal structure than those in the stateful protocol. Because that structure is visible only to the ACS's and gateways of their issuing organization, this allows some flexibility in their use.

One possibility is to use different cryptosystems for visa generation and signature generation. Since signatures cover entire datagrams, they are best done with an inexpensive single-key system such as DES. On the other

<sup>10</sup>The size of a cache entry is twice the size as it is in the stateful protocol; this is because both cleartext and ciphertext versions of visas are cached.

hand, visas themselves are relatively small, and given the caching scheme described in Section IV-D, visa decryption is done infrequently. Visas could therefore be generated using a public-key system such as RSA. Use of a public-key organizational key instead of a single-key one would reduce the dangers of compromising the secret organizational key, since it would never leave the ACS.

It is also possible to include additional datagram-header fields in the visa, thereby allowing visas to be issued on, for example, a process-to-process basis rather than a host-to-host basis. Additional informational fields for use by gateways, such as a limit on the packet rate or packet count for the connection, could also be included in the visa. Any additional visa fields, however, increase the processing time in both hosts and gateways, and risk exceeding limits on datagram header size.

## V. EVALUATION AND COMPARISON OF SINGLE-KEY PROTOCOLS

In this section, we evaluate and compare the two proposed protocols on the basis of their respective overhead costs. We separate the costs into per-connection costs and per-datagram costs for authorized datagrams. Per-connection costs include the extra datagrams exchanged among visa hosts, ACS's, and gateways, as well as the storage requirements in gateways and hosts. Per-datagram costs include encryption and decryption, additional packet length due to the visas, and table lookups in hosts and gateways.

### A. Per-Connection Costs

In the stateful protocol, there are several kinds of per-connection costs.

1) *Negotiations (Supported by Datagram Exchanges) Between  $H_{src}$  and the ACS's Involved*: At least 2 datagrams must be sent to request the necessary visas, and at least 2 datagrams are required to return the visas to  $H_{src}$ .<sup>11</sup>

2) *Distribution of Visas from ACS's to Gateways (More Datagram Exchanges)*: Visas must be passed to at least two visa-gateways ( $GW_{exit}$  and  $GW_{entr}$ ); this requires at least two datagrams. In total,  $M + N$  such datagrams are sent if there are  $M$  potential exit gateways and  $N$  potential entrance gateways.

3) *Table Storage Space and Maintenance Costs*: Storage overhead, consisting of both space and runtime costs, is introduced in this protocol mainly by the need for all participants, but especially gateways, to keep visa-tables. Significant costs are associated with both the space required to store the table, because many connections may be active, and the cost of lookups, since one is performed for every datagram forwarded.

In the stateless protocol, some per-connection costs are reduced.

1) *Distribution of Visas from ACS's to Gateways*: This is not done at all. The only communication between

ACS's and gateways is the distribution of keys at infrequent intervals.

2) *Table Storage Space and Maintenance Costs*: Since the only state stored in the visa-gateways is the cache of decrypted visas, which can be refilled at minimal cost, there is no need to maintain a complete table. Table storage space can be allocated to the extent that it is available. Average per-datagram costs will increase if the cache size is so small as to significantly reduce hit ratios.

The stateless protocol does require each ACS to perform an encryption operation to create a visa. It is also more expensive, in the stateless protocol, to revoke an unexpired visa because there is no way to do this without revoking all unexpired visas.

Overall, the minimum number of datagrams required to set up a connection in the stateless protocol is lower at least by two (more precisely, by  $M + N$ ) since no visa distribution to gateways is done. In addition, the table storage space and maintenance costs are lower for the stateless protocol.

### B. Per-Datagram Costs

The per-datagram costs for visas are the additional fields in datagrams, table look-ups, and cryptographic operations.

Each datagram must carry header fields for both exit and entrance visas. In the stateful protocol, space is required only for two rather small visas, each being a data signature. In the stateless protocol, space is required not only for two data signatures, but also for two rather large visas, each containing (in encrypted form) two source addresses, a signature key, and an expiration time.

In our implementation using 32-bit DES keys, the visas in the stateful protocol together require 8 bytes, while in the stateless protocol, the two visas and data signatures together require 40 bytes (see Fig. 2; note that IP requires an additional 4 bytes to indicate the presence of this option). This difference between the stateful and stateless protocols cannot be ignored, but is becoming less significant as network bandwidths increase.

Both protocols require essentially the same number of table lookups; the cache lookups done in the stateless protocol should cost about the same as the table lookups required in the stateful protocol. The only difference is the size of the lookup key, which is twice as large in the stateless protocol.

The cryptographic operations required depend upon the data integrity scheme used. They also depend upon whether the operation involves passing over the entire datagram or over only part of the datagram. For the single-key visa protocols described in this paper, the cryptographic costs are: 4 cryptographic operations for the stateful protocol, 6 operations for the stateless protocol without cache hits, and 4 operations for the stateless protocol with cache hits (see Table II). These values include the cryptographic operations at the source host and at both intervening gateways.

<sup>11</sup>In practice, any visa protocol may require additional datagrams to be generated in order for  $H_{src}$  to authenticate itself to  $ACS_{src}$  and  $ACS_{dst}$ .

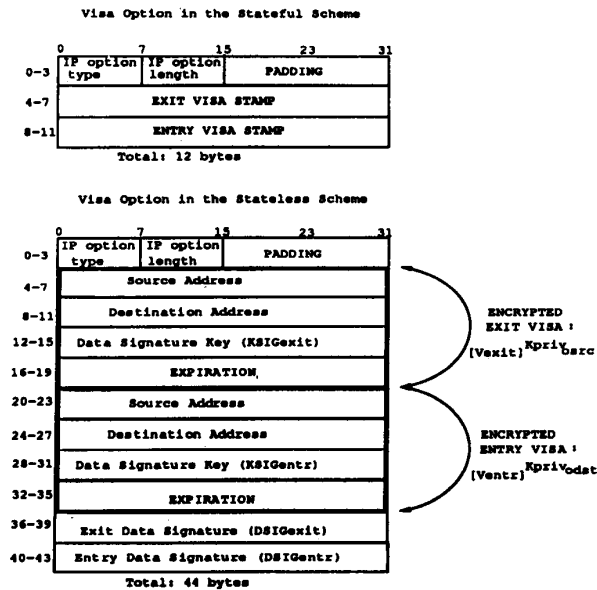

Fig. 2. Visa option definitions.

Using this analysis, we see that, given a reasonable cache hit rate for the stateless protocol, the per-datagram encryption costs are roughly equal for the two single-key visa protocols. The main determinant of cryptographic cost is the strength of the signature function, and thus the vulnerability of the system, rather than the particular visa protocol.

### C. Summary

In summary, the stateless visa protocol has lower setup costs, possibly lower storage costs for the gateways (depending upon the cache size), but slightly higher per-datagram processing costs than the stateful protocol. A natural consequence of this statement is that the stateless protocol provides for more efficient handling of brief connections, since its setup cost is lower; in particular, the critical path is shorter by one packet delay. For longer connections, once the difference in setup costs has been amortized and the gateway caches are loaded, the stateless protocol is slightly less efficient because it requires longer packet headers. A choice between the stateless and stateful protocols may depend on other factors, such as the higher cost of selective revocation in the stateless protocol, and the higher cost of gateway table overflow in the stateful protocol. Alternatively, one could implement a hybrid protocol that would employ either the stateless or the stateful protocol depending upon the connection type.

Either protocol depends upon the availability of a high-performance cryptosystem. While public-key methods do not yet appear to meet this need (the fastest commercially available hardware, the Cylink Corporation CY1024, is specified to encrypt up to 2 kbits/s [2]), single-key systems such as DES are already capable of matching high-speed LAN bandwidths (the AMD AMZ8068 is specified to encrypt up to 1.7 Mbytes/s [11]).

## VI. EXPERIMENTAL RESULTS

The purpose of our experiments was to evaluate per-datagram, connection setup, and overall network costs of visa protocols. This section presents a brief description of our implementation, and analyzes performance measurements of a prototype implementation of both stateful and stateless protocols.

We conducted two sets of experiments—the first on a logical internet in our laboratory at USC, and the second across the DARPA Internet. The laboratory data provide a basis for comparing the relative overheads of the various visa protocols presented. The Internet data prove the feasibility of implementing visa protocols in an operational internet environment, and illustrate the relatively low overhead of visas in a context of relatively high transmission delay.

### A. Visa Implementation

For both laboratory and Internet experiments, visa protocols were implemented as modifications to the IP code in 4.3BSD UNIX running on IBM PC RT's.<sup>12</sup> Visa-gateways, hosts, and ACS's all used RT's with 4 Mbytes of internal memory. The RT's were connected to an Ethernet with standard Ungerman-Bass Ethernet adaptors. DES encryption, in Electronic Code-Book (ECB) mode, was computed in hardware using prototype cards from the Information Technology Center of Carnegie-Mellon University (CMU-ITC). Although the AMD AMZ8068 chip used on the card is specified to encrypt up to 1.7 Mbytes/s [11], the prototype board itself encrypts large data blocks at only 200 kbytes/s due to slow I/O.

The IP option definitions for both visa protocols are depicted in Fig. 2.

We encountered a significant problem with our first implementation of the stateless protocol—we exceeded the maximum IP header size of 60 bytes! In order to implement the stateless protocol within existing IP, we cut down the size of DES keys and data signatures from 64 to 32 bits. Although clever encoding techniques could be used to pack additional key bits into the header, the stateless protocol is unlikely to coexist with any other IP options, due to the header length limit.

### B. Experimental Configurations

For the laboratory experiments, we created logically separate networks on top of a single physical network by manipulating the routing databases for local hosts (see Fig. 3).

Our Internet configuration consisted of networks in two universities, USC and UCLA. The visa networks sit within campus networks which each connect to the ARPAnet (see Fig. 4).

<sup>12</sup>The IBM PC RT scores 2690 on the "Dhrystone benchmark," compared to 2993 for SUN 3/50 and 1577 for Digital Equipment Corporation MicroVax II.

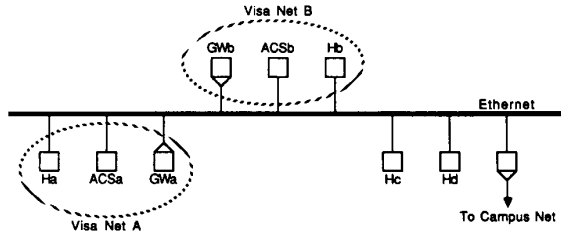

Fig. 3. Laboratory configuration. Logically separate networks on a single physical network.

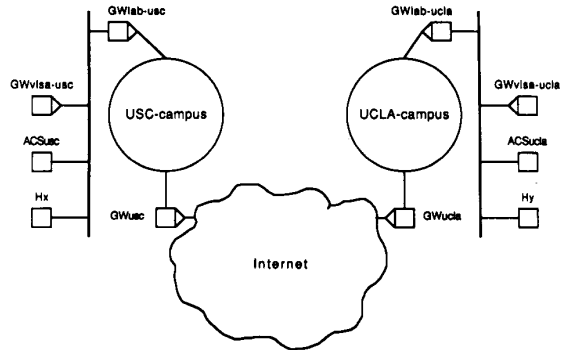

Fig. 4. Internet configuration. Physical connections between USC and UCLA visa networks.

C. Laboratory Measurements

In the laboratory experiment, we measured the roundtrip datagram times for both visa and nonvisa implementations under conditions of similar network load. We measured six protocol variations: no visas, the stateful and stateless visa protocols without encryption (to measure the overhead due to the additional header length of visa packets), the stateful protocol, and the stateless protocol with and without cache hits.

After the initial connection setup, datagram roundtrip time was measured using the ICMP Echo protocol [17]. In this protocol, a request datagram travels from  $H_{src}$  to the  $H_{dst}$ , which immediately returns a reply datagram. We used ICMP Echo instead of an application protocol (such as file transfer or remote login) to isolate, as much as possible, the overhead associated with the visa protocols.

Table I shows measured roundtrip datagram times for datagrams of varying data length. The results are also presented in graphical form in Fig. 5. The slight performance advantage of the stateful protocol comes from the shorter header used, compared to the stateless protocol.

A significant portion of the visa protocol overhead is due to encryption. Table II summarizes the per-datagram cryptographic costs for the three variations described in Sections III and IV. Note that the encryption overhead for the stateless protocol with cache hits is the same as that for the stateful protocol. The table gives one-way overhead; for the roundtrip measurements we made, twice as many encryptions are performed.

TABLE I  
ROUNDTRIP DATAGRAM TIMES FOR THE LABORATORY EXPERIMENT

Version	Packet Size (bytes)					
	16	64	256	500	750	900
Without VISA	10	11	21	32	42	49
Stateful without encryption	12	14	23	34	46	52
Stateful	19	23	40	61	83	95
Stateless without encryption	14	16	25	36	48	54
Stateless with cache hits	20	25	41	63	84	96
Stateless with no cache hits	24	29	44	66	88	100

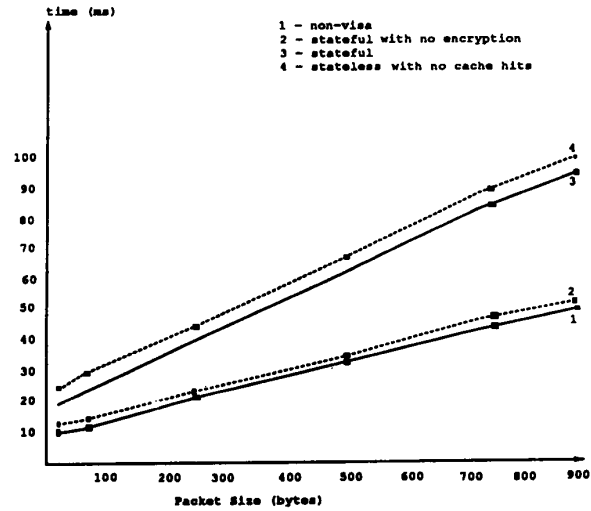

Graph of the round trip measurements in the lab environment

Fig. 5. Graphical representation of the laboratory results.

TABLE II  
PER-DATAGRAM CRYPTOGRAPHIC OPERATIONS

Operation	Version		
	Stateful	Stateless with no cache hits	Stateless with cache hits
$H_{src}$ creates $V_{ent}$	X		
$H_{src}$ creates $V_{entr}$	X		
$H_{src}$ creates $DSIG_{ent}$		X	X
$H_{src}$ creates $DSIG_{entr}$		X	X
$GW_{ent}$ checks $V_{ent}$	X	X	
$GW_{entr}$ checks $V_{entr}$	X	X	
$GW_{ent}$ checks $DSIG_{ent}$		X	X
$GW_{entr}$ checks $DSIG_{entr}$		X	X
TOTAL NUMBER	4	6	4

Actual measurements of the total encryption costs are shown in Table III.

These measurements correspond closely to calculations based upon the number of encryption operations. For example, a roundtrip for a 1 kbyte datagram requires 8 encryptions; at an encryption rate of 200 kbytes/s, encrypting 8K bytes should take 40 ms. The measured value is 53 ms. The discrepancy comes from per-datagram overhead in using the encryption hardware, which is not reflected in the nominal 200 kbyte/s rate (measured for encryptions of much larger data blocks).

Since it should be possible to employ the AMZ8068 DES chip to encrypt data at up to 1.7 Mbyte/s, we also present an estimate, in Table IV, of the roundtrip times attainable with encryption at the realistically attainable

TABLE III  
PER-DATAGRAM ENCRYPTION COSTS OF STATEFUL AND STATELESS VISA  
PROTOCOLS

Overhead due to encryption					
Version	Packet Size (in bytes)				
	16	64	500	1000	
Stateful	8	10	31		53
Stateless with cache hits	8	10	31		53
Stateless with no cache hits	13	15	38		58

TABLE IV  
PROJECTED ROUNDTRIP TIMES FOR THE LABORATORY EXPERIMENT WITH 1.0  
MBYTES/S ENCRYPTION RATE

Version	Packet Size (bytes)				
	16	64	250	500	900
Stateful	12	14	24	38	56
Stateless with no cache hits	14	17	28	38	51
Stateless with cache hits	14	16	28	38	58

rate of 1.0 Mbyte/s, this illustrates the importance of faster DES hardware.

The connection setup time for the stateful visa protocol ranged from 30 to 40 ms, averaging about 33 ms. This number represents the time from when the first unstamped datagram is sent to the time that the visa arrives at  $H_{src}$ , allowing stamped datagrams to be sent. The REJECT mechanism is employed, but the ACS to GW communication is not secured by encryption or other privacy mechanisms.

#### D. Internet Measurements

The laboratory Ethernet has higher bandwidth, and is more lightly loaded, than the typical interorganizational network. Therefore, we also conducted experiments over the DARPA Internet to demonstrate the visa protocols in a more realistic context. The path between USC and UCLA included a highly congested, low-bandwidth (56 kbit/s) hop, as well as several nonvisa-gateways.

In this configuration, not only is the average delay much higher, but the *variance* in queuing delay is larger than the difference between the visa and nonvisa protocol overheads. Consequently, we must emphasize that the results *cannot* be used to compare the various visa protocols to one another, but are presented primarily to demonstrate the reduced significance of visa overhead in the context of other sources of network delay.

In order to obtain the most meaningful average values for visa and nonvisa protocols, we ran suites of measurements of different times of the day and week in search of a period of relatively low delay variance. The numbers presented in Table V (and graphically in Fig. 6) are from a suite run during a 3-hour interval when delay varied least. In addition, we excluded the highest delay values when calculating the averages for each protocol.

These measurements may understate the cost of visa protocols, since the encryption operations involved were probably being performed in parallel with the transmission of other packets over a congested link. In an uncongested network, through gateways that handle only visa-controlled datagrams, this parallelism might not be

TABLE V  
ROUNDTRIP DATAGRAM TIMES FOR THE INTERNET EXPERIMENT

Version	Packet Size (bytes)					
	16	64	250	500	750	900
Without VISA	120	149	280	441	609	696
Stateful without encryption	131	172	298	468	618	706
Stateful	138	176	316	478	631	719
Stateless with no cache hits	190	228	342	507	661	745

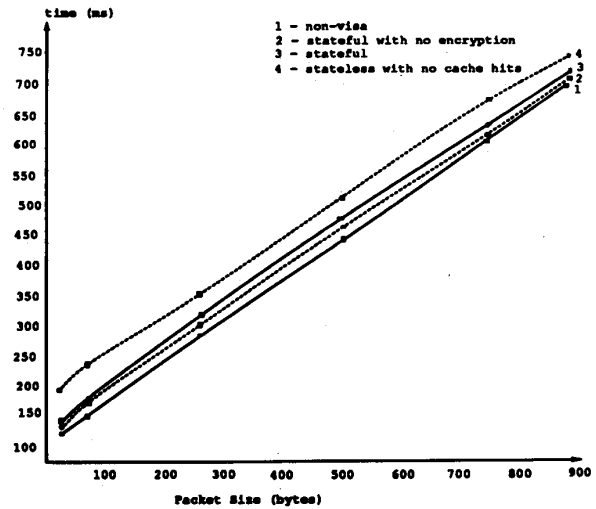

Graph of the round trip measurements in the internet environment

Fig. 6. Roundtrip travel time across the Internet for datagrams of varying length.

available, and the additional end-to-end delay imposed by the visa protocols could be as large as it is in our laboratory experiments.

#### E. Analysis

Our results demonstrate the function of the stateful and stateless protocols in both laboratory and actual interorganizational internet arrangements. They show that, while the overhead for our implementation is significant, it is not prohibitive.

The laboratory results provide a basis for comparing the protocols to one another. They confirm our prediction that the stateless protocol performs nearly as well as the stateful one, on per-datagram delay, when the cache-hit rate is reasonably high. (In the operating region where the number of active conversations is greater than the size of a gateway's visa-table, the stateless protocol may perform better than the stateful protocol.) These results also show that when comparing the cost of connection setup in the stateful protocol to the cost of setting up cache entries in the stateless protocol, for connections involving only a few datagrams, the stateless protocol may have a small edge. In the steady state, the difference in delay of approximately 2 ms per datagram is due to the additional length of stateless-protocol visa options.

The Internet results demonstrate that when visa mechanisms are added to subsets of existing Internet gateways

and hosts, both variations of the protocol work without interfering with nonvisa, local network, or internet operations. These results also demonstrate that the overhead of visa protocols is much less significant in high-delay environments. The results from the laboratory experiments provide an upper bound on the overhead of visa protocols; the relative overhead in actual interorganizational networks will be lower, since over such paths the delays due to visa protocols stay fixed, while delays due to transmission and gateway processing generally are higher.

The critical prerequisite for practical application of visa protocols is faster encryption hardware. If encryption rates are not improved by an order of magnitude over that of the equipment we used, visa-related encryption processing will present an overwhelming burden to high-speed gateways that can otherwise process several thousand packets per second. We believe that acceptable encryption rates are feasible with current technology.

#### VII. OTHER DESIGN ISSUES

Several other design issues are listed below and are discussed in more detail in [6].

- *Access Control and Denial of Service:* Overall security of an organization's network depends upon ACS to host and GW communication security. There is also the possibility of denial of service through harassment of ACS's with REQUEST messages. In addition, visa protocols do not prevent all replay of valid messages (if done while a visa key is valid).

- *Reducing the Cost of Connection Setup:* The actual cost of connection setup depends upon how an organization chooses to configure its ACS. For example, we assume that two-way visas are allocated automatically. If one-way visas are used, the cost of connection setup will be doubled.

- *Protecting Transit Organizations:* Transit organizations are vulnerable if internal hosts accept datagrams not addressed to them. A transit organization may be protected through the use of encryption-based encapsulation as the datagram traverses the transit net.

- *Visas and Fragmentation:* The visa protocols described make use of data signatures. Fragmentation results in a change in (that is, truncation of) the data contents of a packet. However, fragmentation can be accommodated if necessary (see [20] and [9]).

- *Covert Channels via Header Fields:* A data signature method must cover not only the data segment, but any datagram header fields whose authenticity cannot be checked by the gateways. Any unchecked field leaves a potential covert channel, since a malicious host could copy a valid datagram, change the unchecked field, and send the modified copy without raising suspicion. It is easy to reduce the bandwidth of this channel to only a few bits per packet; it is nearly impossible to reduce it further.

- *Implications for Internet Gateway Design:* Combining the functions of a conventional Internet gateway with that of a visa-gateway represents a challenge to

gateway designers. The increased number of possible error conditions and cost of encryption processing overhead makes achievement of high throughput more difficult.

#### VIII. CONCLUSIONS

We have described two variations on the original visa scheme [4] for controlling datagram flow between organizations. The first involves direct transfer of authentication information between ACS's and gateways, state maintenance in the gateways, and a cryptographic mechanism to mark authorized datagrams. In the second variation, authentication information is "piggybacked" on the controlled datagrams, rather than directly communicated between ACS's and gateways, and the gateways maintain caches rather than true databases. The two protocols vary in the number of packets required to authorize a connection, their behavior under load and during failure recovery, and the amount of encryption performed on each datagram; experimental results illustrate these tradeoffs.

Adaptation of visas in actual internetworks depends on several prerequisites: resolution of a few design choices and parameters; the widespread availability of inexpensive, fast, and secure cryptosystems; and sufficient coordination among organizations to make the system worthwhile. Visas are at best a robust *mechanism* for enforcing information flow control *policies*; the choice and specification of these policies will present difficult and interesting problems.

#### ACKNOWLEDGMENT

Our thanks to numerous colleagues in the Internet community for their comments on previous drafts, including: B. Braden, A. de Schon, M. Schroeder, R. Sansom, and the anonymous reviewers.

Particular appreciation to: K. Anand for implementing the Internet experiments; P. Crumley of the Carnegie-Mellon University ITC for making available the DES hardware and assisting us in putting it to work; M. LaRouche of UCLA for providing temporary access to UCLA network facilities in support of our Internet experiments; and to M. Brown of the USC Computing Services for helping to configure our experimental laboratory internet.

#### REFERENCES

- [1] D. W. Davies and W. L. Price, *Security for Computer Networks*. New York: Wiley, 1984.
- [2] W. Diffie, "The first ten years of public-key cryptography," *Proc. IEEE*, vol. 76, pp. 560-577, May 1988.
- [3] W. Diffie and M. E. Hellman, "New directions in cryptography," *IEEE Trans. Inform. Theory*, vol. IT-22, pp. 644-654, Nov. 1976.
- [4] D. Estrin and G. Tsudik, "Visa scheme for inter-organization network security," in *Proc. IEEE Symp. Security and Privacy*, Apr. 1987, pp. 174-183.
- [5] D. Estrin, "Interconnection protocols for interorganization networks," *IEEE J. Select. Areas Commun.*, vol. SAC-5, pp. 1480-1491, Dec. 1987.
- [6] D. Estrin, J. Mogul, G. Tsudik, and K. Anand, "Visa protocols for controlling inter-organization datagram flow: Extended description," Univ. Southern Calif., Comput. Sci. Dep., Tech. Rep. TR 88-50, Dec. 1988.

- [7] D. Estrin and G. Tsudik, "Security issues in policy routing," to appear in *Proc. IEEE Symp. Res. in Security, Privacy*, May 1989.
- [8] J. G. Fletcher and R. W. Watson, "Mechanisms for a reliable timer-based protocol," *Comput. Networks*, vol. 2, no. 4/5, pp. 271-290, Sept./Oct. 1978. (Also in *Proc. Comput. Network Protocols Symp.*, Feb. 1978, pp. C5.1-C5.17.)
- [9] C. Kent and J. Mogul, "Fragmentation considered harmful," in *Proc. ACM SIGCOMM 1987*, Aug. 1987, pp. 390-401.
- [10] J. Mracek, "Network access control in multi-net internet transport," S.B. thesis, Dep. Elec. Eng. Comput. Sci., M.I.T., June 1983.
- [11] *Advanced Micro Devices MOS Microprocessors and Peripherals Data Book*, Advanced Micro Devices, Inc., Sunnyvale, CA, 1987.
- [12] *Federal Information Processing Standards*, National Bureau of Standards, Publ. 46, 1977.
- [13] R. M. Needham and M. D. Schroeder, "Using encryption for authentication in large networks of computers," *CACM*, vol. 21, no. 12, pp. 993-998, Dec. 1978 (note also CSL-78-4, Xerox Palo Alto Res. Center, Sept. 1978).
- [14] —, "Authentication revisited," *Operating Syst. Rev.*, vol. 21, no. 7, p. 7, Jan. 1987.
- [15] M. A. Padlipsky, *A Perspective on the ARPANET Reference Model*, NIC, RFC 871, Sept. 1982.
- [16] J. Postel, *Internet Protocol*, NIC, RFC 791, Sept. 1981.
- [17] —, *Internet Control Message Protocol*, NIC, RFC 792, Sept. 1981.
- [18] R. Rivest, A. Shamir, and L. Adleman, "A method for obtaining digital signatures and public-key cryptosystems," *CACM*, vol. 21, no. 2, pp. 120-126, Feb. 1978.
- [19] A. Tanenbaum, *Computer Networks*, Englewood Cliffs, NJ: Prentice-Hall, 1981.
- [20] G. Tsudik, "Datagram authentication in internet gateways: Implications of fragmentation and dynamic routing," this issue, pp. 499-504.
- [21] R. W. Watson, "Delta-T protocol preliminary specification, UCRL 52881, Lawrence Livermore Lab., Nov. 1979.
- [22] H. Zimmermann, "OSI reference model—The ISO model of architecture for open systems interconnection," *IEEE Trans. Commun.*, vol. COM-28, pp. 425-432, Apr. 1980.



**Deborah Estrin** (S'78-M'85) received the B.S.E.E. degree from UC Berkeley in 1980; the M.S. degree in technology policy from the Massachusetts Institute of Technology, Cambridge, in 1982; and the Ph.D. degree in computer science from M.I.T. in 1985.

She has conducted research in the area of network interconnection, autonomy, and security for the past six years. She is an Assistant Professor of Computer Science at USC (since 1986).

Dr. Estrin received the National Science Founda-

tion, Presidential Young Investigator Award for her research in network interconnection and security. She is Chairperson of the Internet Activities Board, Autonomous Networks Task Force; a member of the National Science Foundation's NSFNET Technical Advisory Committee; and acts as a reviewer for several IEEE and ACM journals and conferences. She is a member of ACM, AAAS, and CPSR.



**Jeffrey C. Mogul** received the S.B. degree from the Massachusetts Institute of Technology in 1979, the M.S. degree from Stanford University in 1980, and the Ph.D. degree from the Stanford University Computer Science Department in 1986.

He has been an active participant in the Internet community, and is the author or co-author of several Internet Standards. Since 1986 he has been a Researcher at the Digital Equipment Corporation Western Research Laboratory, working on network and operating systems issues for high-

performance computer systems.

Dr. Mogul is a member of ACM, Sigma Xi, and CPSR.



**Gene Tsudik** (S'88) received the B.S. degree in computer science from the University of Houston in 1985 and the M.S. degree in computer science from the University of Southern California in 1987.

He is currently a Ph.D. candidate at the University of Southern California conducting research in the Computer Networks and Distributed Systems Laboratory. He is also employed by the IBM Los Angeles Scientific Center as a Student Researcher. His research interests include com-

puter networks, security and expert systems.

Mr. Tsudik is a member of FDIC and ACM.